

FARMI®

Forest

Made in Finland



FARMI®

SKIDDING WINCHES

The complete forest cable winch programme
for rational timber harvesting

FARMI FOREST - PROGRESSIVE FOREST MACHINES SINCE 1962

Farmi Forest Corporation is one of the the worlds leading manufacturer of forest machines. FARMI FOREST forest machines are sold worldwide under the trade mark "FARMI" and "Farmi Forest".

Farmi range consist of

- Farmi winches
- Farmi and Primero log loaders and forest trailers
- Farmi wood chippers



The reliable cable winch generation

Farmi, known worldwide for its forest equipment, offers a large scale of 3 point linkage mounted cable winches. Its over forty years of pioneer work in the field of forestry is its guarantee for development and the safety features of its machine and equipment.

With the close cooperation of manufacturers and users throughout the world, we are able to customize our equipment to the requirements of different countries and customers.

Farmi's state-of-the-art technology and top quality standards, guarantees the continued production of quality products.

Our worldwide distribution network and experienced staff will be happy to help you pick the machine that best fits your needs and take your interests to the factory so as to meet your personal requirements.

A fast delivery service of spare parts has always contributed to the success of our customer relationship policy. The prerequisite for effective workmanship and maximization of profitability involves a correct product selection as well as an optimum working environment.

Farmi has developed for each skidding method, the adequate accessories to carry out your task successfully in all working environments, increasing productivity and obtaining from

your tractor its best performance. This is the result of a long standing relationship among producers, users and forestry offices. Farmi cable winches use a modular design system complying with safety regulations and equipped with all the corresponding safety features.

The complete forest cable winch programme for rational timber harvesting

- Modular design
- High pulling efficiency
- User friendly
- Optimum cable spooling device
- Reliable and sturdy clutch
- Drum overrun brake
- Top safety level
- Long life



Function and operation

These linkage mounted winches have a cable drum driven by the tractor's running power by means of a cardan shaft and chain transmission equipped with a mechanical friction clutch. The winch is operated by means of control cables (All-round operation) or as an option through an electrohydraulic control set. The drum comes with an adjustable

overrun device so as to prevent overrun when pulling out the winch cable. Farmi winches come in two versions: with automatic safety brake (T-model) or with ratchet brake. T- models have an automatic self-boosting hand-brake (dead-mans' brake principle), which responds immediately when needed.

1. PTO-shaft
2. chain drive
3. friction plate
4. cable drum
5. cable
6. drum overrun brake
7. band brake (in T-models)

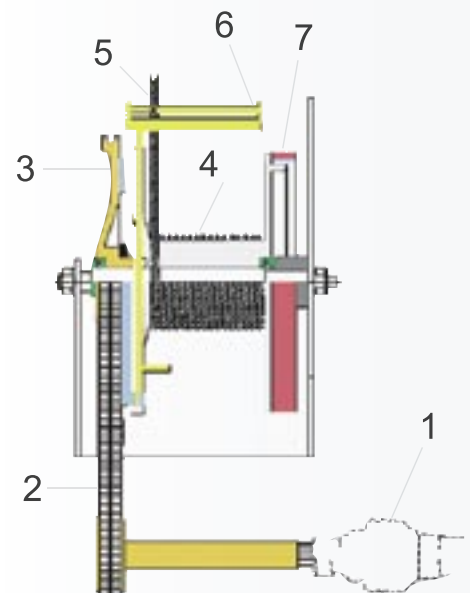

THE RELIABLE CABLE WINCH GENERATION - OVER 43 YEARS OF EXPERIENCE



JL 351 P - JL 351 PT - JL 450T ^{NEW!}

A series of Farmi single drum winches with 3.5 t or 4,5 t pull. This lightweight product is the ideal cable winch for small tractors from 15 HP on, JL 450T from 35 HP.

Standard models include the upper cable pulley and ample butt plate with notched beam. The winch comes with the option of a lower guide-pulley.

JL 501 - JL 501 T

The Farmi single drum winch with 5 t pull for tractors from 35 HP on.

Series manufactured with an integrated butt plate and a vertically adjustable lower cable pulley: a light, stable and reliable winch.



JL 601 - JL 601 T

The Farmi single drum winch with 6 t pull for tractors from 60 HP. This series is manufactured with vertically adjustable lower guide-pulley and a covered tool box.

Some products in the pictures may include accessories which are not standard. These items have to be ordered separately.

Why is Farmi the most popular three point cable winch worldwide? Its success in in the details.



A high pivoted cable entry guarantees optimum spooling into the cable drum (A), minimizing ground damage by slightly lifting the load. The high entry also generates down thrust on the butt plate, which improves stability during winching.

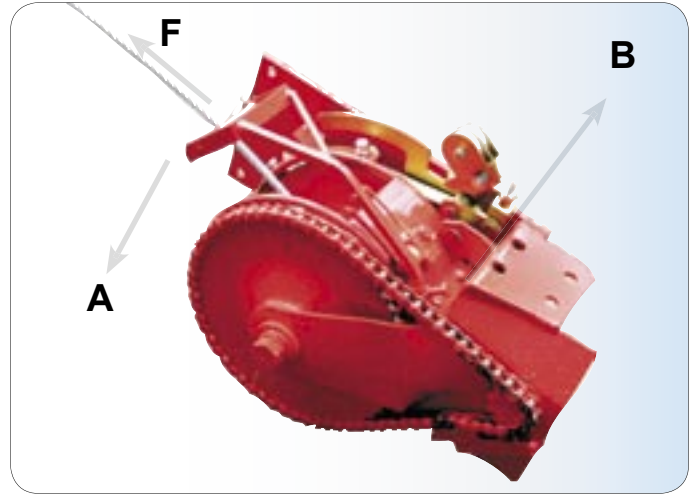

The automatic over-running brake device guarantees a very smooth pull-out of the cable and prevents run on. Thus the cable remains tight on the drum and tangle-free. When pulled from the cable (F). Then lever (A) moves towards the drum and releases the brake (B).



The lower pivoted guide-pulley is for pulling heavier loads with small tractors. The guide pulley block has a hinged check-plate for easy reeling. Vertically adjustable on models JL 501 / 601.

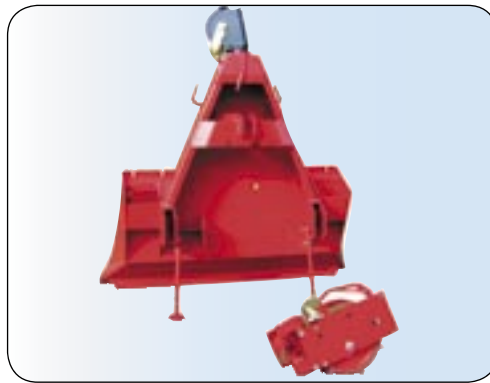

Modules are constructed so as to facilitate servicing and repairs. The complete winch module can be dismantled from its support structure. External adjustment and clutch readjustments can be easily and quickly performed.



A single frame lightweight construction avoiding unnecessary welding seams, provides a long, above average workinglife with optimum protection of module parts, which translates into extended writeoff time, which in turn, equals a low investment.



Because the cable which is closely attached to the tractor, this improves stability and enables the efficient skidding of high loads without lifting the tractor's front axle.



The clutch operates by means of a control cord which can be used from all directions (revolving pulley). This operation provides good controlled clutch coupling and release for working precision and safety.



A lasting, well shaped and broad butt plate can be used as a stabilizer when winching, supporting the logs when skidding and dozer to pile logs.

ACCESSORIES FOR FARMI FOREST CABLE WINCHES

Electrohydraulic steering with manual or remote control.



The Farmi-HOF electrohydraulic control consists of a hydraulic pump, electric motor cylinder and hydraulic tank, thus forming an integrated independent system.

The control unit uses 12 volts from the tractor and operates independently from the tractor's hydraulic system.



A sturdy weatherproof control box, with a 5 m long plug-in cable controls the winch by means of a twist knob and a push button.

The Farmi-cable winch can therefore be controlled mechanically (by means of a dragline), electrohydraulically, or by remote control.

The carefully measured coupling and braking operation is guaranteed for all three control options. It is therefore possible to pull slowly and to carefully lower the load.

Electrohydraulic steering with manual or remote control.



Tool box (JL 601, JL 601T)

SEE OTHER FARMI WINCHES: www.farmiforest.fi



JL 85 Alp, JL 75 Alp, JL 55 Alp



HYDRAULIC WINCH FOR CRANES



EV 300



JL 2/601T
DOUBLE DRUM



JL 351



JL 290

OTHER AVAILABLE ACCESSORIES:



Protective screen between winch and cab



Choker chain 2 m & 2,5 m



Choker hitch



Skid grapple



Natched hook



Skid pan



Cable guides



Self-releasing snatch block

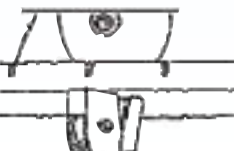

Lower guide-pulley



Cable

With deadman brake

TECHNICAL DATA	JL351 P	JL501	JL601	JL351 PT	JL450T	JL501 T	JL601T
TRACTIVE POWER MAX., T	3,5	5,0	6,0	3,5	4,5	5,0	6,0
CABLE CAPACITY, Ø MM/M Ø MM/M	8/90 10/60	8/100 10/80	10/130 12/100	8/90 10/60	8/100 10/80	8/100 10/80	10/130 12/100
DRAWING IN SPEED AT 350 U.P.M. M/S DRAWING IN SPEED AT 540 U.P.M. M/S	0,3-0,85 0,5-0,3	0,3-0,9 0,5-1,4	0,36-0,82 0,56-1,26	0,3-0,85 0,5-0,3	0,3-0,9 0,5-1,4	0,3-0,9 0,5-1,4	0,36-0,82 0,56-1,26
WEIGHT WITHOUT CABLE, KG	170	250	390	180	200	265	405
MECHANICAL PLATE COUPLING	yes	yes	yes	yes	yes	yes	yes
THREE POINT LINKAGE	cat. I and II	cat. II	cat. II	cat. I and II	cat. I and II	cat. II	cat. II
POWER NEEDED, HP	from 15	from 35	from 60	from 15	from 35	from 35	from 60
DEADMAN BRAKE	no	no	no	yes	yes	yes	yes
AFTER RUNNING BRAKE OF THE DRUM	yes	yes	yes	yes	yes	yes	yes
TOOL BOX	no	yes	yes, with cover	no	no	yes	yes, with cover
DOZER BLADE AND PULLING-YOKE WITH CHAIN SPRING BOLTS	yes	yes	yes	yes	yes	yes	yes
HOLDERS FOR ALONG CHAINS	yes	yes	yes	yes	yes	yes	yes
LOWER GUIDE PULLEY	option	yes	yes	option	option	yes	yes
CABLE GUIDES	no	yes	yes	no	no	option	option
SAFETY NET	option	option	option	option	option	option	option
REAR COUPLING	option	option	option	option	option	option	option
REMOTE CONTROL	no	no	no	no	option	option	option
HYDRAULIC CONTROL	no	no	no	no	option	option	option

DIMENSIONS

	JL351 P JL351 PT	JL450T	JL501 JL501 T	JL601 JL601 T
A	420	420	1110	1040
B	1320	1320	1500	1800
C	445	445	520	460
D	380	380	420	750
E	1980	1980	2200	2320
F	1500	1500	1680	1820

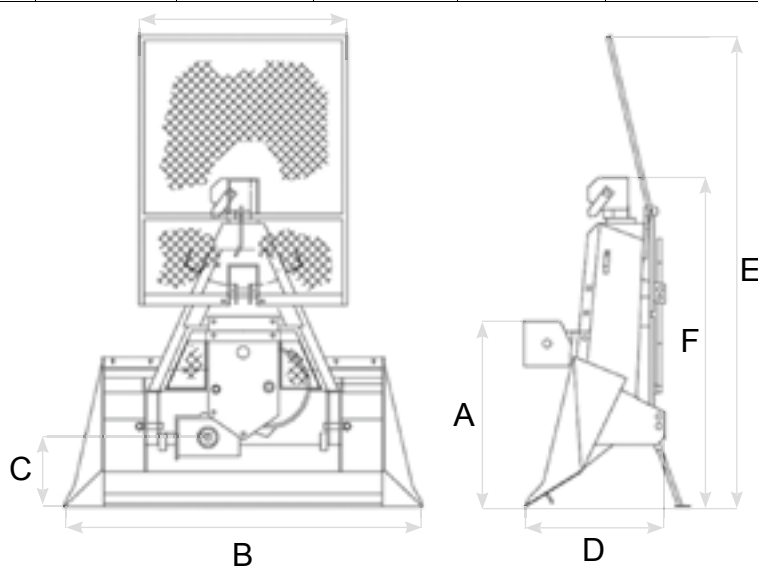

Manufacturer

Distributor